

# DUCO products and ventilation systems

L8000013-G 08.03.2024

## Table of contents

<b>01 DUCO products and systems</b> .....	<b>2</b>	<b>05 Ventilation unit</b> .....	<b>13</b>
01.A Solar screens and window ventilators.....	2	05.A Mechanical Extract Ventilation systems (natural ventilation).....	13
Window ventilators.....	2	Maintenance frequency.....	13
Solar screens with window ventilators.....	2	How to perform checks.....	13
Solar screens without window ventilators.....	2	How to clean.....	14
Louvre grilles.....	2	05.B MVHR: mechanical ventilation with heat recovery.....	15
01.B Ventilation systems: per residential unit vs. collective applications.....	3	Overview.....	16
Ventilation systems per residential unit - which ventilation system do I have?.....	3	Parts.....	17
Ventilation systems - collective applications.....	4	<b>06 Ventilation ducts</b> .....	<b>24</b>
<b>02 Ventilation systems (per residential unit): overview maintenance according to type of ventilation system</b> .....	<b>6</b>	06.A Maintenance frequency.....	24
02.A MEV system - natural ventilation.....	6	06.B How to clean.....	24
02.B MVHR system: mechanical ventilation with heat recovery.....	7	<b>07 Control components and user controllers</b> .....	<b>25</b>
<b>03 Window ventilators</b> .....	<b>8</b>	07.A Maintenance frequency.....	25
03.A Maintenance frequency.....	8	07.B Battery-powered control.....	25
03.B How to clean.....	9	<b>08 Kitchen box</b> .....	<b>26</b>
Window ventilators in general.....	9	08.A Maintenance frequency.....	26
Specific window ventilators.....	9	08.B How to clean.....	26
Window ventilators with integrated solar screen.....	10	<b>09 Service &amp; warranty</b> .....	<b>27</b>
<b>04 Vents</b> .....	<b>11</b>	<b>10 In general</b> .....	<b>28</b>
04.A Maintenance frequency.....	11		
04.B How to clean.....	11		
DucoVent Design.....	11		
DucoVent Premium.....	11		
DucoVent Comfort / DucoVent Auréa.....	11		
DucoVent Basic.....	12		
DucoVent Alizé Auto / DucoVent Alizé Hygro / DucoVent SR (Hygro).....	12		

# 01 DUCO products and systems

## 01.A Solar screens and window ventilators

### Window ventilators

See "03 Window ventilators" on page 8.

### Solar screens with window ventilators

See "03 Window ventilators" on page 8.

### Solar screens without window ventilators

#### **Maintenance and cleaning**

The system requires little maintenance, but to enjoy your system for many years to come, we recommend the following:

- NEVER use a high-pressure cleaner to clean solar shading. This may damage the fabric, but it may also damage stronger metal or plastic parts.
- If the fabric becomes wet due to an unexpected shower, you may simply roll up the screen, and then unroll it again in better weather to allow it to dry. However, make sure not to keep the fabric rolled up wet for more than three days to prevent moulding and stains.
- Remove loose dirt first using a brush or vacuum cleaner before washing down. You can then remove the remaining dirt after using a cleaning agent and lukewarm water (special cleaning products are available from the installer). Always rinse off the fabric after cleaning. Avoid cleaning in bright sunlight: if soapy water dries quickly, it can leave stains on the fabric. Do not use any aggressive scouring agents.
- Hinged or rotating parts need to be lubricated annually. Use a dry lubricant for this (Teflon spray).
- Plastic sliding bushes can be lubricated using a dry lubricant (Teflon spray) after cleaning (remove twigs and leaves).
- As a manufacturer, we recommend a regular technical inspection of your installation by the installer:
  - Annually for non-residential buildings;
  - Every 4 years for domestic solar shading.
- Always use original spare parts from the manufacturer.
- Disconnect the Hirschmann plug inside the cassette when servicing or cleaning the surface behind the solar shading.

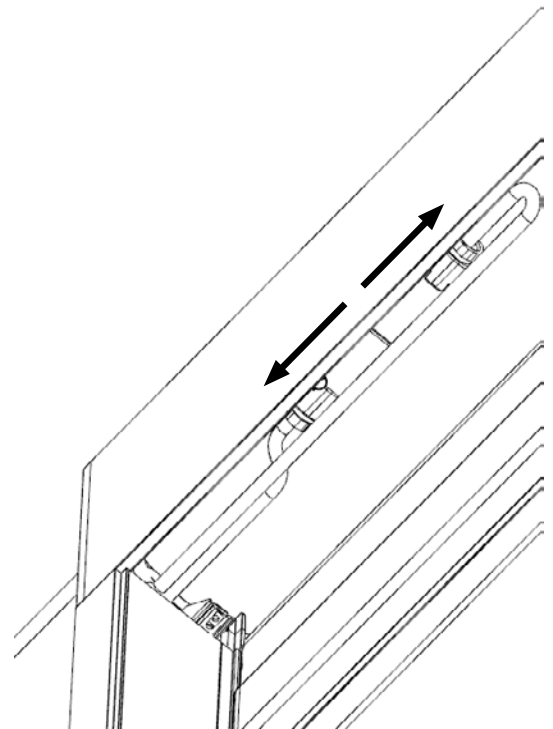

### Louvre grilles

#### **Maintenance and cleaning**

Louvre grilles require little maintenance, but to enjoy your products for years to come, we recommend the following:

- Recommended frequency of maintenance: at least twice a year (or at least 4 times a year if located in an area with aggressive atmospheric conditions or if there are non-sprayed parts); to benefit from the guarantee, proof of cleaning must be presented at all times.
- Remove loose dirt first using a brush or vacuum cleaner before washing down. You can then remove the remaining dirt using a cleaning agent and warm water (special cleaning products are available from the installer). Always rinse off after cleaning.
- Avoid cleaning in bright sunlight: if water with tensioactive agents dries off rapidly it can leave stains behind. Never use solvents such as petrol, acetone, etc. or strongly alkaline or acidic products, nor aggressive abrasives such as sandpaper, scouring pads, etc.

## 01.B Ventilation systems: per residential unit vs. collective applications

### Ventilation systems per residential unit - which ventilation system do I have?

The capabilities of your ventilation system will depend on the configuration of the system. Please contact your DUCO installer if you do not know which ventilation system you have. A DUCO Demand-controlled Ventilation System consists of the following:

- **Central extract unit**  
This unit extracts polluted air when necessary. With MVHR, the unit (DucoBox Energy) also supplies fresh air.
- **Air duct network**  
Via ventilation ducts to various rooms, polluted air is extracted to the ventilation unit (and fresh air is supplied in the case of MVHR). Note: depending on the configuration of your system, not every room is directly ventilated. Rooms in which no exhaust duct is provided are ventilated via transit to other rooms. This can be done, for example, with a grille in the inner doors or an air gap underneath.
- **One or more sensors<sup>1</sup>**  
CO<sub>2</sub> and/or humidity sensors monitor air quality and detect presence. Sensors can be incorporated into a remote control in the room, into air ducts or into the ventilation unit.
- **One or more remote controls**  
For manual operation of the ventilation system.
- **Window ventilators (Mechanical Extract Ventilation only)**  
Fresh air is supplied via window ventilators integrated in the windows, window frames, sliding doors or façade. Your ventilation system may include manual and/or Tronic (= electronically controlled) window ventilators. Manual window ventilators require to be opened and shut by the user. Tronic window ventilators are electronically controlled window ventilators which open and shut automatically as the system sees fit.



**You will need to leave manual window ventilators at least partially open in order to guarantee automatic system operation.**

<sup>1</sup> Exception: DUCO MEV system

## Ventilation systems - collective applications

The only part here that needs regular maintenance (for better efficiency and longer life) is the Duco RoofFan.

### Duco RoofFan

- **Maintenance frequency**

BY WHOM	FREQUENCY	WHAT
Installer	6 months	Check the rotor for abnormal noises and/or vibrations
Installer	2 years <sup>2</sup>	Checking and cleaning the rotor

- **Safety instructions and maintenance tips**



- Do not carry out any maintenance work with the fan running. Always disconnect the motor from the power supply first and secure it against being switched on again.
- Only trained personnel should carry out repair work.
- Defects found must be rectified immediately. If there is any acute danger, the system must not be used in the defective condition.
- Wear safety clothing, safety shoes and cut-resistant safety gloves while working.
- Observe the safety and working regulations (EN 50 110, IEC 364).
- Fuses should only be replaced and not repaired or bridged. The data for the maximum fuse must always be observed (see Technical Data Sheet). Provide only the fuses planned in the electrical diagram. Keep the ducts to the RoofFan free of objects: danger from objects flying out.
- Ensure vibration-free running.
- Observe the limit values specified in ISO 14694 and, if these limits are exceeded, take measures to stop this (such as balancing by qualified personnel).
- The running wheel is subject to natural wear and tear. Deposits on the running wheel can lead to imbalance and thus damage, such as tears, cracks and fractures. Repair of the running wheel by e.g. welding is prohibited.
- Aggressive substances in the exhaust air can lead to corrosion and impeller breakage. Corroded running wheels should be replaced immediately.
- Deposits on the motor and in particular on the cooling ribs and in the recesses on the rotor can result in reduced cooling and the motor shutting down prematurely. Therefore, remove deposits immediately.
- The expected service life of the ball bearings integrated in the motor, determined according to the standard calculation procedure, is determined to a large extent by the service life of the grease F10h and amounts to approx. 30,000-40,000 operating hours in standard application.
- The fan and/or motor is maintenance-free thanks to the use of lubricated-for-life ball bearings. The indicated service life of the grease may become shorter compared to the stated theoretical value (F10h) due to operating conditions such as vibrations, moisture or dirt in the bearing, unfavourable types of regulation, etc.
- Bearings cannot be replaced. In case of problems with the bearings, a completely new rotor must be installed.

<sup>2</sup> If unusual soiling is detected at the 6-monthly check for vibration or abnormal noises, the cleaning interval should be adjusted to 6 months or even shorter, as needed.

## • Cleaning



- Always disconnect the motor from the power supply first and secure it against being switched on again.
- Clean the flow area of the fan.
- Do not use aggressive, paint-dissolving cleaning agents.
- Make sure that no water gets inside the motor and into the electronics (e.g. through direct contact with seals or motor openings). Keep to the type of protection (IP).
- Check the condensate drain holes (if present) matching the installation position for free passage.
- In the event of improper cleaning procedures, no guarantee will be given in respect of corrosion / paint damage on unpainted / painted fans.
- In order to prevent moisture accumulation in the motor, the fan should be driven for at least 1 hour at 80 to 100% of its maximum speed before the cleaning process!
- After the cleaning process, the motor should be driven for at least 2 hours at 80 to 100% of its maximum speed to dry it!

## • Gaining access to the rotor

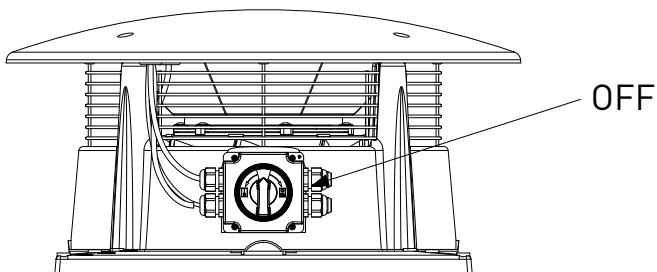

- 1** De-energise the roof exhaust fan by turning the emergency load switch from the ON to the OFF position. Ensure that the power cannot be switched back on by, for example, providing a mechanical lock on the emergency load switch.

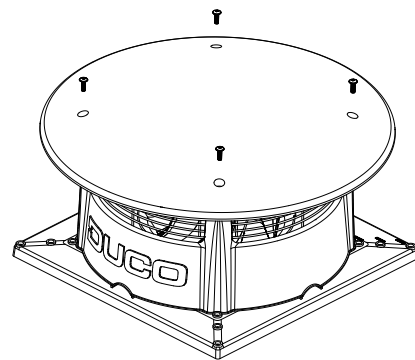

- 2** Remove the lid of the roof exhaust fan by unscrewing the 4 Allen bolts.

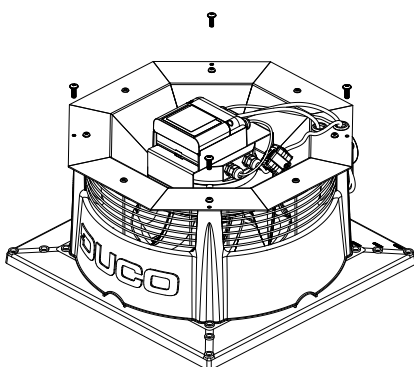

- 3** Remove the motor plate with rotor and control unit from the middle injection molding by unscrewing the 4 plastic screws.

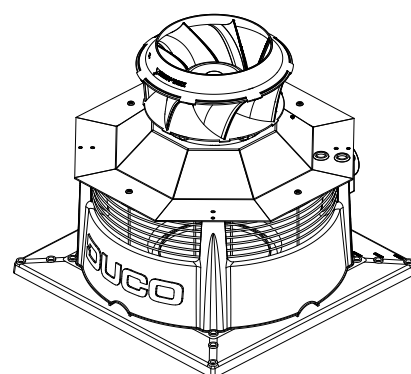

- 4** Turn the motor plate with rotor and control unit 180° and place it on the middle injection molding. Screw the motor plate back to the middle injection molding with at least 2 plastic screws to avoid shifting (and damage) during cleaning.

# 02 Ventilation systems (per residential unit): overview maintenance according to type of ventilation system



Always ensure that before maintenance work begins, the device is isolated from the mains supply by removing the power cord from the wall socket or by switching off the fuse. Check by measurement that this is actually the case.

## 02.A MEV system - natural ventilation

**INSTALLER**

**RESIDENT**

The colour indicates who should carry out which maintenance

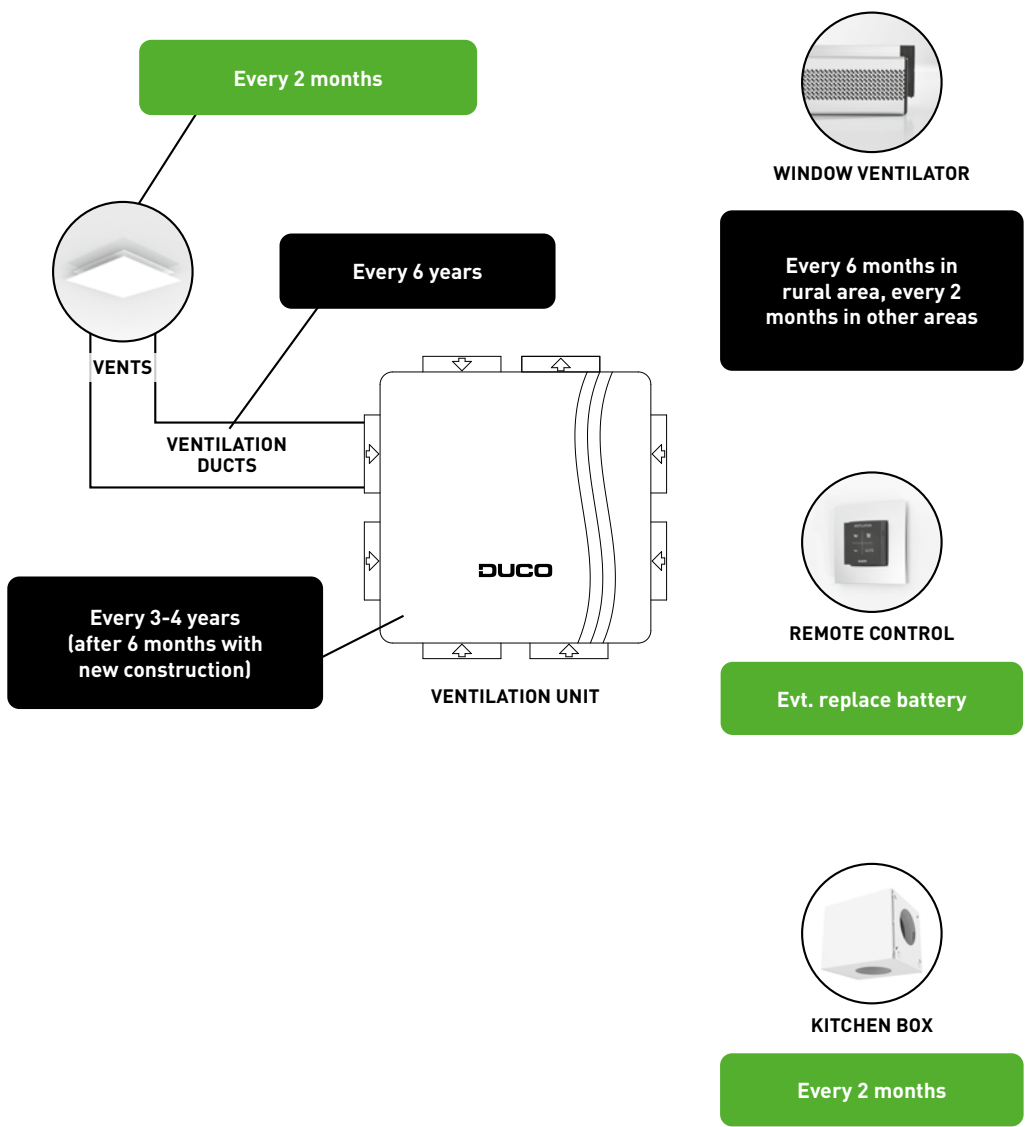

## 02.B MVHR system: mechanical ventilation with heat recovery

**INSTALLER**

**RESIDENT**

The colour indicates who should carry out which maintenance

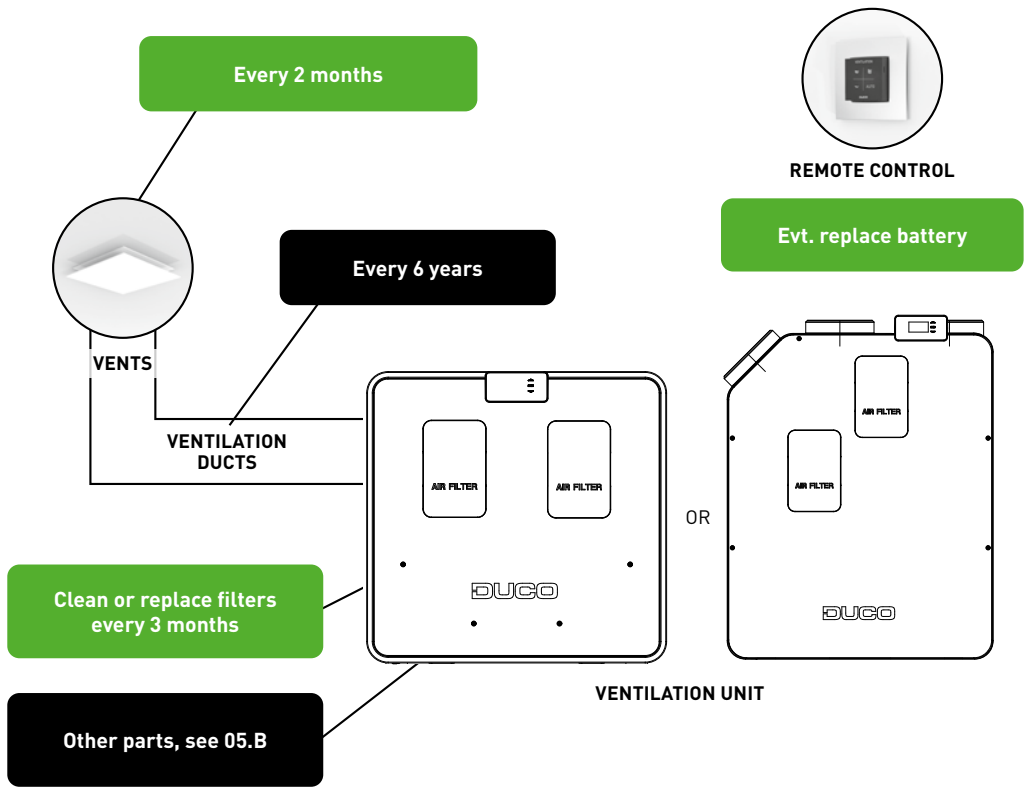

## 03 Window ventilators

### RESIDENT



On the DUCO website ([www.duco.eu](http://www.duco.eu) - see more specifically [duco.tv](http://duco.tv)) you can find a number of maintenance videos for window ventilators.

Window ventilators require little maintenance, but to enjoy year-round use of your window ventilators, optimum operation and healthy indoor air quality, we would advise the following.

- Window ventilators can be cleaned very quickly and easily for optimum ventilation.
- Failure to carry out these maintenance operations may result in the control malfunctioning or failing to operate at all.
- You are strongly advised against the use of abrasives (e.g. sandpaper or scouring pads), pressure washers and harsh cleaners (e.g. solvents or ammonia).

### 03.A Maintenance frequency

#### RESIDENT

#### INSTALLER

- Check the window ventilators regularly (approximately once every 2 months) for fouling. You will need to clean the window ventilators in case of fouling.
  - Cleaning twice a year is sufficient in rural surroundings.
  - If you live in an urban environment, next to an industrial area or on the coast, you will need to clean your window ventilators 6 times a year.
- Hinged or rotating parts need to be lubricated annually. Use a dry lubricant for this (Teflon spray).
- Window ventilators with solar screens: As the manufacturer, we recommend regular technical check-ups on your system by the installer
  - Annually for non-residential buildings
  - Every 4 years for domestic solar shading
- For electronically controlled window ventilators: Regularly inspect the wiring for damage. Changes to the electrical part may only be carried out following the manufacturer's approval.



## 03.B How to clean

### INSTALLER

### Window ventilators in general

- Put the ventilation flap in fully open position, for manual window vents by using the operation (handle or crank), for electronically controlled (Tronic) vents by pressing position 3 of the linked control/room sensor.
- If the window ventilator has a removable insect-resistant inner grid, remove it by hand.  
→ It is advisable to carry out this operation with 2 people if the length of the window ventilator is over 1,500 mm.
- Clean the removable inner grid with a vacuum cleaner and then with a damp cloth (soap and water (e.g. a general-purpose cleaner)).
- Fouling on the inside, including the ventilator flap or the rotary barrel mechanism, of the window ventilator is best removed by sucking out or cleaning using a vacuum cleaner, brush or duster/damp cloth. Carefully check also for fouling that may have accumulated in the corners. If so, remove it as well.
- If applicable, put the inner grid back on the window ventilator.
- With an electronic (Tronic) window ventilator: press AUTO on the corresponding user controller/room sensor again.

### Specific window ventilators

#### **DucoFit 50 'SR' / EasyFit 50 'SR'**

- Take the removable insect repellent inner grid off by using a flat-blade screwdriver.
- Remove the left-hand and right-hand control.
- Remove the ventilation flap from the inner grid.
- Clean the removable inner grid and the gutter with a vacuum cleaner and then wipe out well with a damp cloth (soap and water (e.g. a general-purpose cleaner)).
- Fouling on the inside of the window ventilator is best removed by sucking out or cleaning using a vacuum cleaner, brush or (damp) cloth. Carefully check also for fouling that may have accumulated in the corners. If so, remove it as well.
- Put the ventilation flap correctly back into the inner grid.
- Reinstall the left-hand and right-hand controls correctly.
- Put the inner grid back on the window ventilator.

#### **DucoTop 60 SR**

- Manually set the ventilation flap to the fully open position.
- Press the plastic end piece (left and right-hand side) inwards using a flat screwdriver.
- Take the removable insect repellent inner grid off by hand.  
→ It is advisable to carry out this operation with 2 people if the length of the window ventilator is over 1,500 mm.
- Clean the removable inner grid with a vacuum cleaner and then with a damp cloth (soap and water (e.g. a general-purpose cleaner)).
- Fouling on the inside of the window ventilator is best removed by sucking out or cleaning using a vacuum cleaner, brush or (damp) cloth. Carefully check also for fouling that may have accumulated in the corners. If so, remove it as well.
- Put the inner grid back on the window ventilator.

## **Window ventilators with integrated solar screen**

### **Ventilation section**

- See above: window ventilators in general

### **Fabric blind**

- If the fabric becomes wet due to an unexpected shower, you may simply roll up the blind, and then unroll it again in better weather to allow it to dry. However, make sure not to keep the fabric rolled up wet for more than 3 days to prevent moulding and stains.
- Remove loose fouling first using a brush or vacuum cleaner before wiping.
- You can then remove the remaining dirt after using a cleaning agent and lukewarm water (special cleaning products are available from the installer).
- Always rinse off the fabric after cleaning.
- Avoid cleaning in bright sunlight: if soapy water dries quickly, it can leave stains on the fabric. Do not use any aggressive scouring agents.

### **Lateral guides**

(= maintenance of frame and arms)

- It is recommended that you should have the hinge pins, wheel shafts and bearings on your solar shading checked once a year.
- DUCO recommends to clean your articulated arms (for the CAP version) using a damp sponge (soap and warm water (e.g. a general-purpose cleaner)).
- Lubricate the pivoting or rotating components after cleaning your solar shading.
- A dry lubricant (Teflon spray) can be applied to plastic guide blocks and aluminium guide sections after cleaning.
- A dry lubricant (Teflon spray) needs to be applied to diagonal or horizontal sections in which guide blocks slide.
- Plastic sliding bearings can be lubricated using a dry lubricant (Teflon spray) after cleaning (remove twigs and leaves).

# 04 Vents

## RESIDENT



On the DUCO website ([www.duco.eu](http://www.duco.eu) - see more specifically [duco.tv](http://duco.tv)) you can find a maintenance video for DucoVent Design.

Air is extracted from kitchens, bathrooms and toilets through vents. These are usually incorporated in the ceiling.

Take care not to change the setting and position of the vent control mechanism. Make sure that the vents are not interchanged, i.e. that they are put back in their original ventilation opening in the wall or ceiling. All this may affect the flow rate and the proper functioning of the ventilation system.

### 04.A Maintenance frequency

- As a resident, you need to carry out the inspection and cleaning yourself.
- Check the vents regularly (approximately once every 2 months) for fouling.
- Clean the vent with a damp cloth as soon as you notice any fouling.

### 04.B How to clean

#### DucoVent Design

- Remove the aluminium cover plate, which is attached with magnets, from the actual vent.
- The cover plate can now be cleaned with a damp cloth (soap and water (e.g. a general-purpose cleaner)). Never immerse the aluminium cover plate in water, so as to protect the magnets.
- Take the acoustic foam pack out of the vent. The foam can be cleaned using a vacuum cleaner. The plastic part with a damp cloth.
- The inside of the duct can be cleaned with a vacuum cleaner.
- Place the acoustic foam pack back in the vent. Make sure that the foam is inserted up to the top of the ceiling section.
- Place the cover plate back on the vent. It is attracted by the 4 magnets and positions itself.

#### DucoVent Premium

These valves require little maintenance, provided (in the case of an MVHR system) the filters are regularly cleaned and/or replaced.

- DO NOT remove the vent from the plaster ring (risk of damaging the ceiling).
- Clean the vent opening with a brush and a vacuum cleaner.
- Clean the visible parts of the vent with a damp cloth (water and soap (e.g. an all-purpose cleaner)).

#### DucoVent Comfort / DucoVent Auréa<sup>3</sup>

- In case of light soiling:
  1. In case of light soiling, wipe the vents with a slightly damp cloth.
  2. If necessary, use a solution of a mild cleaner (washing-up liquid/general-purpose cleaner).
- In case of strong dirt adhesion, remove the vents completely from the duct.
  1. Take hold of the outer edge of the vent and pull it completely out of the wall or ceiling with a twisting movement.
  2. Immerse the vents completely in a solution of general-purpose cleaner.
  3. Wipe the vents off with a cloth or soft brush.
  4. Dry the vents.
  5. Place each vent back into its original duct.

<sup>3</sup> Only in France

## DucoVent Basic

- In case of light soiling:
  1. In case of light soiling, wipe the vents with a slightly damp cloth.
  2. If necessary, use a solution of a mild cleaner (washing-up liquid/general-purpose cleaner).
- In case of strong dirt adhesion, remove the vents completely from the duct.
  1. Take hold of the outer edge of the vent and pull it completely out of the wall or ceiling with a twisting movement.
  2. Remove the foam rubber sealing strip.
  3. Immerse the vents completely in a solution of general-purpose cleaner. If necessary, the vents can be cleaned in the dishwasher.
  4. Wipe the vents off with a cloth or soft brush.
  5. Dry the vents. Place the foam rubber sealing strip back onto the vent.
  6. Place each vent back into its original duct.

## DucoVent Alizé Auto / DucoVent Alizé Hygro / DucoVent SR (Hygro)<sup>4</sup>

- Remove the grid (4) and the control module (3)<sup>5</sup> from the base (2) of the vent. If the base is dirty, also remove it from the connector (1).

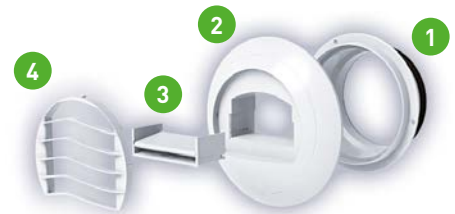

**Never disconnect the connector itself from the ventilation duct!**

- Immerse the parts of the vent completely in a solution of general-purpose cleaner. If necessary, the vents can be cleaned in the dishwasher.
- Wipe the vents off with a cloth or soft brush.
- Dry the vents.
- Reinstall the vent parts.
- Place each vent back into its original duct connector.

<sup>4</sup> Some of these vents are only available in France.

<sup>5</sup> The control module and the base look slightly different on the DucoVent ZR (Hygro), but the method of operation remains the same.

# 05 Ventilation unit



See [www.duco.eu](http://www.duco.eu) (more specifically [duco.tv](http://duco.tv)) for a whole series of maintenance instructions about DucoBox Energy Comfort (Plus), DucoBox Energy Premium, DucoBox Focus and DucoBox Silent (Connect)

## 05.A Mechanical Extract Ventilation systems (natural ventilation)

### Maintenance frequency

#### RESIDENT

#### INSTALLER

- Before (possibly) proceeding to clean your extract unit, as a resident, you need to inspect it to establish whether it is necessary.
- Your central extract unit needs to be cleaned by an accredited installer.
- In a newbuild home, the DucoBox needs to be cleaned completely, i.e. including Box Sensors and Control valves (if present), after 6 months.
- After these 6 months, you will need to repeat this operation every 3 – 4 years, depending on the degree of fouling.
- If the central extract unit is used in combination with an extractor hood, then maintenance will be required more frequently than indicated above. This will require additional maintenance, such as cleaning / replacing filters, the motor and the Box sensors plus Control valves, if present.
- Technical maintenance of the DucoBox is not necessary.

### How to perform checks

#### INSTALLER

1. De-energise the DucoBox.
2. Open the lid.
3. Unclip the extract unit plate in 4 places by releasing the 4 snap-ins with a flat screwdriver.
4. Do not touch the internal electronics.
5. The extract unit plate can then be removed from the casing.
6. Check the impeller for contamination. A small amount of fouling has little effect on the extract unit's performance. If the fouling is more than 1 mm thick on the inside of the blades, we advise you to have them cleaned.
7. Check the bearings. You can do this by turning the impeller by hand.
8. Check the bearings for noise.
9. Check that the fan is not swinging.
10. When the fan is set in motion by hand, it only makes a few revolutions and then comes to a standstill with some jerks. This is a characteristic of a DC extract unit and is therefore entirely normal.
11. Depending on the outcome of the inspection, the extract unit will need to be cleaned and/or prepared for use.
12. Clip the extract unit plate back into the casing.
13. Check to ensure it is positioned correctly and press hard.
14. Close the lid. Press well on the 4 corners.
15. Put the DucoBox under tension again.

## **How to clean**

### **INSTALLER**

#### **DucoBox Silent / DucoBox Silent FR / DucoBox Hygro**

1. De-energise the DucoBox.
2. Open the lid.
3. Remove the wiring from the extract unit plate and Box sensor(s) connected, if present, by unclipping them from the connector on the PCB.
4. Unclip the extract unit plate in 4 places by releasing the 4 snap-ins with a flat screwdriver.
5. Do not touch the internal electronics.
6. The extract unit plate can then be removed from the casing.
7. Clean the fan and the casing with a vacuum cleaner.
8. Under no circumstances clean the motor unit with water and definitely do not immerse it in water or any other detergent.
9. The fan's volute can be cleaned with a damp cloth.
10. Dry the fan's volute with a dry cloth.
11. Clip the extract unit plate back into the casing.
12. Check to ensure it is positioned correctly and press hard.
13. Take the Box sensors, if present, out of the casing and clean them with a vacuum cleaner or a dry cloth.
14. Put the Box sensors back, if present, ensuring that each of them is connected to the correct room / the correct duct.
15. Reconnect all the wiring.
16. Close the lid. Press well on the 4 corners.
17. Put the DucoBox under tension again.

#### **DucoBox Focus / DucoBox Hygro Plus**

1. Open the lid.
2. Note which duct is connected where. Label the ducts.
3. Press the button on each Control valve, if present. The LED indicator lights up as a result and then dims.
4. Wait for 10 seconds while the Control valves, if present, shut automatically.
5. De-energise the DucoBox.
6. Remove the wiring from the extract unit plate and Control valves connected, if present, by unclipping them from the connector on the PCB.
7. Unclip the extract unit plate in 4 places by releasing the 4 snap-ins with a flat screwdriver.
8. Do not touch the internal electronics.
9. Clean the fan and the casing with a vacuum cleaner.
10. Under no circumstances clean the motor unit with water and definitely do not immerse it in water or any other detergent.
11. The fan's volute can be cleaned with a damp cloth.
12. Dry the fan's volute with a dry cloth.
13. Clip the extract unit plate back into the casing.
14. Check to ensure it is positioned correctly and press hard.
15. Take the Control valves, if present, out of the casing and clean them with a vacuum cleaner or a dry cloth.
16. Put the components back again, ensuring that each Control valve, if present, is connected to the correct room, in line with the nominal extract flow rate for each room.
17. Reconnect all the wiring.
18. Close the lid. Press well on the 4 corners.
19. Put the DucoBox under tension again.

## DucoBox Reno

1. De-energise the DucoBox.
2. Open the lid.
3. If present, disconnect the CO<sub>2</sub> Box sensor cable from the PCB.
4. Unclip the fan plate in 4 places by loosening the 4 snap-in fasteners with a flat screwdriver and remove the power cable's strain relief from the recess.
5. Do not touch the internal electronics.
6. The extract unit plate can then be removed from the casing. When doing so, pay attention to the opening through which the CO<sub>2</sub> Box sensor cable, if present, is fed.
7. Clean the extract unit and the casing with a vacuum cleaner or brush.
8. Under no circumstances clean the motor unit with water and definitely do not immerse it in water or any other detergent.
9. The fan's volute can be cleaned with a damp cloth. When doing so, be careful not to get water on the RH sensor electronics (part behind perforated protrusion in the scroll).
10. Dry the fan's volute with a dry cloth.
11. Take the CO<sub>2</sub> Box sensor, if present, out of the casing and clean it with a vacuum cleaner or a dry cloth.
12. Put the CO<sub>2</sub> Box sensor back, if present, ensuring that it is connected to the correct room / the correct duct.
13. If present, thread the CO<sub>2</sub> Box sensor cable through the correct opening of the fan plate and snap the fan plate back into the casing.
14. Check to ensure it is positioned correctly and press hard.
15. Slide the power cable's strain relief back into the casing's recess.
16. Close the lid. Press well on the 4 corners.
17. Put the DucoBox under tension again.

## 05.B MVHR: mechanical ventilation with heat recovery

In order to ensure that the ventilation system will operate correctly, the unit must be inspected and maintained at periodic intervals at a number of points. A well-maintained unit has a positive impact on efficiency, runs quieter and boasts a longer service life.

DUCO advises in the event of any fault or abnormal operation to refer to your installer and not carry out repairs yourself.



**Always pull the plug out of the power socket or isolate the unit from the power supply before carrying out maintenance or repairs.**

## Overview

### RESIDENT

ITEM	WHAT	PERIOD	ACTION
Filters	Check for contamination	3 months	Clean filters
	Replace filters	6 months	Replace filters
Vents / window ventilators	Check for contamination	6 months	Clean filters
Unit	Check for abnormal noises	1 year	Inform the installer

### INSTALLER

ITEM	WHAT	PERIOD	ACTION
Unit	Check for abnormal noises	1 year	Check the fan and valve(s)
Siphon flat (DUCO condensate drain)	Check for correctly operating condensate drain + clean	2 years	Clean condensate drain
Filters	Replace filters	1 year	Replace filters if necessary
Vents / window ventilators	Check for contamination	1 year	Clean the filters, if necessary
Fans	Check + clean fans	4 years	Clean fans
Heat exchanger	Check + clean heat exchanger	2 years	Cleaning the heat exchanger
Bypass valve	Check bypass operation	4 years	Control + clean bypass valve
2-zone valve / multi-zone valve (optional)	Check + clean	4 years	2-zone valve cleaning
Pre-Heater (optional) (only with Comfort (Plus))	Check + clean	4 years	Checking + cleaning the Pre-Heater
Integrated frost protection (Premium only)	Check + clean	4 years	Clean frost-protection module
Casing	Check	4 years	Check + deal with damage or corrosion phenomena
Ducts	Clean supply ducts	5-6 years	Clean ducting network
	Clean exhaust ducts	8 years	Clean ducting network



## Parts



Also visit [duco.tv](https://duco.tv) for step-by-step instructional videos.

## Filters

### RESIDENT

The filters of your DucoBox Energy should be replaced at least every six months.

**NOTE:** The filters require to be replaced within 3 months after initial commissioning in order to remove building dust and so on, even if the unit is not indicating it. Failure to clean (sufficiently) or replace filters (on time) can lead to a poorly functioning ventilation system with unnecessarily high consumption, increased noise and unhealthy air for residents.

Warranty on the unit will be void if:

- components not supplied by the manufacturer are used
- the unit is used without filters

### 1. Cleaning the filters

In general, DUCO recommends cleaning the filters every 3 months. If after 3 months it would appear that the filters are already too dirty, cleaning can be scheduled at shorter intervals.

Navigate via the display to **FILTER** -> **CLEAN FILTER** and follow the steps described:

- Remove the filter caps.
- Clean filters
  - Use a vacuum cleaner and move in the direction of the filter folds.
  - Make sure that the filters are pushed back into the device in the same position.
- Close filter caps
- Press enter (■)



**Make sure that the filters are not rotated when they are removed for inspection or cleaning.**

### 2. Replacing filters

#### Replace filter indication

The system indicates that the filters need to be replaced by means of an alert on the DucoBox Energy display:

- Alert on display: "**REPLACE FILTERS**", display stays lit up until the user takes action. This alert appears once.
- Alert on display, when the previous alert has been deleted by the user: alert symbol at the top of the display + filter indication shows 0%.

The estimated remaining service life of the filter is indicated in two ways:

- At the top right of the display is the filter indicator:
  - FILTER: 20%**
  - 100% = new filter
  - 0% = replace filter
- The estimated remaining life of the filter (expressed in days) can be read in the menu **FILTER** -> **FILTER STATUS**

#### Postponing filter replacement

When the message "**REPLACE FILTERS**" appears on the display, you can postpone this until you have received the new filters. You can do this by selecting "**NO**" when the alert appears on the display for the first time. You will not receive any new messages to replace the filters after that.

The alert symbol (⚠) will remain visible at the top of the display by way of a reminder; furthermore, this filter indication will show 0%.



**You will not receive a new notification; you must take action yourself to replace the filters.**

### Ordering filters

Filters can be ordered from your DUCO dealer. There is a choice between the following sets:

TYPE	ARTICLE NUMBER
Filter set 2 x Coarse 65% (Energy Premium)	0000-4417
Filter set Coarse 65% / ePM1 55% (Energy Premium)	0000-4416
Filter set 2 x Coarse 65% (Energy Comfort D325)	0000-4661
Filter set Coarse 65% / ePM1 55% (Energy Comfort D325)	0000-4417
Filter set 2 x Coarse 65% (Energy Comfort D400 / Comfort Plus)	0000-4741
Filter set Coarse 65% / ePM1 55% (Energy Comfort D400 / Comfort Plus)	0000-4742

The filtersets for the DucoBox Energy contain the following filters:

For supply air (SUP): choice between Coarse 65% ( $\approx$  G4) or ePM1 55% filter ( $\approx$  F7). The ePM1 55% filter allows fewer fine particles through, which has a positive influence on air quality (e.g. for people who may have allergies).

For extract air (ETA): Coarse 65% filter ( $\approx$  G4)

### 3. Replacing filters

#### Step 1: order NEW filters

To guarantee the unit's correct operation and a healthy indoor climate, you are strongly advised against re-using contaminated filters (e.g. after vacuum-cleaning them). This can result in a breeding-ground for bacteria and an unhealthy indoor climate!

#### Step 2: order the CORRECT filters

Press enter (■) when the message "REPLACE FILTERS" is visible and select **YES**, or navigate to the menu **FILTER -> REPLACE FILTER**.



When an "ePM1 ( $\approx$  F7)" filter is used, it must be used in the supply air flow (SUP).

Depending on the version, the supply is at the following location:

With a DucoBox Energy Premium:

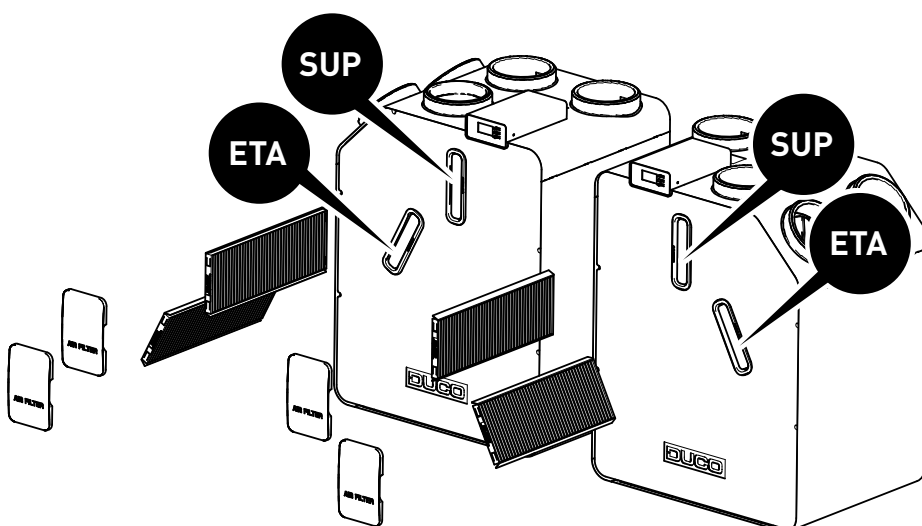

**With a DucoBox Energy Comfort (Plus):**

The SUP position depends on the version: Left (L) or Right (R):

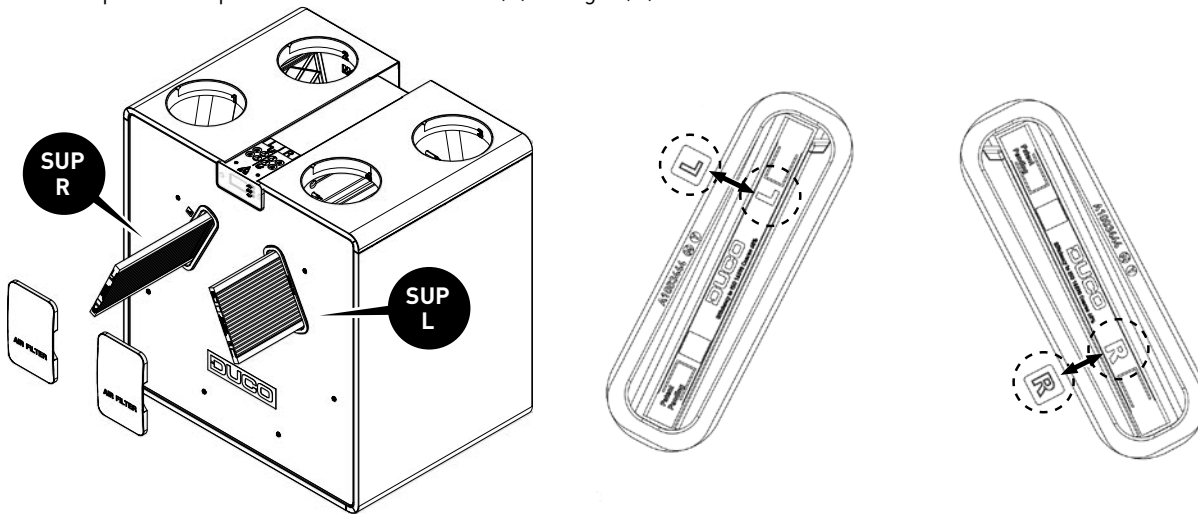

Version L or R can be consulted via the display: **INFO -> DEVICE INFO**. Also make sure the filter is fitted correctly. "L" and "R" on the filter must match the "L" and "R" on the front plate of the ventilation unit!

**Step 3: Follow the instructions on the display when replacing the filters**

- a. Remove the filter caps.
- b. Replace the filters.
- c. Close the filter caps.
- d. Confirm using enter (■).

## INSTALLER

### Unit

1. Check the outside for damage. The DucoBox Energy needs to be switched on for this check. Keep clear from moving parts and beware of electric cables.
2. Switch the unit to the 3 settings and check whether the DucoBox Energy speeds up and slows down correctly in order to test the rpm setting.

### Heat exchanger

1. Switch off the unit.
2. Remove the screws and take the front plate off the unit.
3. Mark the position of the heat exchanger to enable you to fit it back in the same position.
4. Pull the heat exchanger out of the unit by the provided strap. Do not cut the strap, it is there to pull the heat exchanger out of the unit.
5. Check the heat exchanger for contamination.
6. To remove dust or dirt, we immerse the heat exchanger in warm water a few times; we can rinse it off with warm water (40 °C max.).
7. Shake the heat exchanger dry.
8. Fit the heat exchanger back into the unit once it is dry enough.
9. Fit the front plate back onto the unit. Tighten the screws sufficiently to ensure that the unit is sealed airtight.

### Fans

#### 1. Fan of a DucoBox Energy Comfort (Plus)

- a. Switch off the unit.
- b. Remove the screws and take the front plate off the unit.
- c. Mark the position of the heat exchanger to enable you to fit it back in the same position.
- d. Pull the heat exchanger out of the unit by the provided strap. Do not cut the strap, it is there to pull the heat exchanger out of the unit. This is necessary in order to gain proper access to the bypass.
- e. Use a vacuum cleaner and damp cloth to remove all the dust.
- f. Fit the heat exchanger back into the unit.
- g. Fit the front plate back onto the unit. Tighten the screws sufficiently to ensure that the unit is sealed airtight.

#### 2. Fan of a DucoBox Energy Premium

- a. Switch off the unit.
- b. Remove the screws and take the front plate off the unit.
- c. Disconnect the two plugs on the fan and slide the fan out of the unit by pulling it towards you.

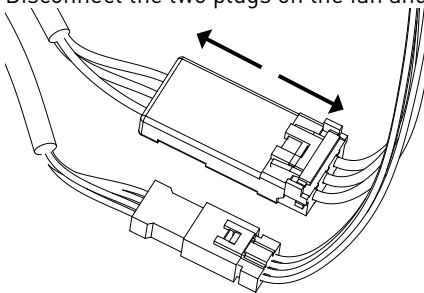

- d. Check the casing and fan blades for contamination and damage.
- e. Use a soft brush to clean the casing and fan blades.
- f. Use a vacuum cleaner to remove all the dust.
- g. Reconnect the two plugs on the fan.
- h. Fit the front plate back onto the unit. Tighten the screws sufficiently to ensure that the unit is sealed airtight.

## **Modulating bypass**

1. Switch off the unit.
2. Remove the screws and take the front plate off the unit.
3. Mark the position of the heat exchanger to enable you to fit it back in the same position.
4. Pull the heat exchanger out of the unit by the provided strap. Do not cut the strap, it is there to pull the heat exchanger out of the unit. This is necessary in order to gain proper access to the bypass.
5. Check the bypass for contamination or damage and clean it if necessary.
6. Fit the heat exchanger back into the unit.
7. Fit the front plate back onto the unit. Tighten the screws sufficiently to ensure that the unit is sealed airtight.

## **2-zone valve (DucoBox Energy Premium)**

See the specific video instructions for maintenance of the 2-zone valve of the DucoBox Energy Premium on [duco.tv](https://duco.tv)

## **Multi-zone valve (DucoBox Energy Comfort (Plus))**

See the specific video instructions for maintenance of the multi-zone valve of the DucoBox Energy Comfort (Plus) on [duco.tv](https://duco.tv)

## Pre-Heater

### 1. Integrated Pre-Heater (only with a DucoBox Energy Premium)

2. Switch off the unit.
3. Check to ensure the unit is isolated from the power supply.



**ELECTROCUTION HAZARD! Do not proceed if the device is still live!**

4. Remove the screws and take the front plate off the unit.
5. Disconnect the Pre-Heater from the power supply.

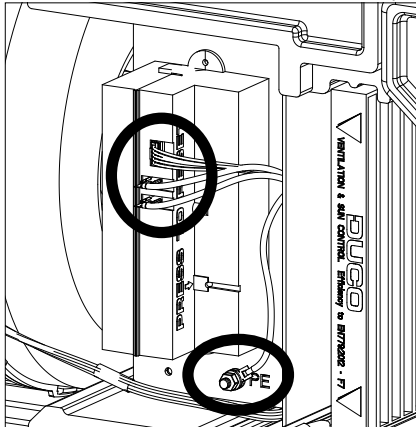

6. Slide the pre-heat module out of the unit.
7. Check the module for contamination or damage.
8. Clean the module using a soft brush. Do not use water!
9. Slide the module back into the unit and switch the power supply back on.
10. Fit the front plate back onto the unit. Tighten the screws sufficiently to ensure that the unit is sealed airtight.

### 2. Optional Pre-Heater (only with a DucoBox Energy Comfort (Plus))

See also the specific video instructions for maintenance of the Pre-Heater of the DucoBox Energy Comfort (Plus) on [duco.tv](http://duco.tv)

1. Check via the display that there are no Heater Warnings or Errors.
2. Switch off the unit.
3. Check that the unit and the Pre-Heater are de-energised.



**ELECTROCUTION HAZARD! Do not proceed if the device is still live!**

4. Open the lid at the back of the Pre-Heater.
5. Disconnect the Pre-Heater from the power supply and data connectors.
6. Measure out the power connectors (first without, then with power).
7. De-energise the device again.
8. Slide the heater block out of the casing.
9. Check the module for contamination or damage.
10. Clean the module with a soft brush and damp cloth.
11. Also clean the internal casing.
12. Slide the heater block back into the casing and reconnect the power supply and data cable.
13. Close the lid of the Pre-Heater.
14. Put the plugs of both Pre-Heater and DucoBox back into the socket.

## Condensate drain

### 1. DucoBox Energy Comfort (Plus)

- a. Switch off the unit.
- b. Remove the screws and take the front plate off the unit.
- c. Mark the position of the heat exchanger to enable you to fit it back in the same position.
- d. Pull the heat exchanger out of the unit by the provided strap. Do not cut the strap, it is there to pull the heat exchanger out of the unit.
- e. Check whether there is any water left in the condensate drain and pour some water into the trap to check its operation. By doing so you will also ensure that a (standard) trap is filled to the optimum level in order to obtain an airtight system (water in a trap can evaporate at higher temperatures).
- f. Check the drainage path downstream for blockages if the water does not drain off properly.
- g. Fit the heat exchanger back into the unit.
- h. Fit the front plate back onto the unit. Tighten the screws sufficiently to ensure that the unit is sealed airtight.

### 2. DucoBox Energy Premium

- a. Switch off the unit.
- b. Remove the screws and take the front plate off the unit.
- c. Check whether there is any water left in the condensate drain and pour some water into the trap to check its operation. By doing so you will also ensure that a (standard) trap is filled to the optimum level in order to obtain an airtight system (water in a trap can evaporate at higher temperatures).
- d. Check the drainage path downstream for blockages if the water does not drain off properly.
- e. Fit the front plate back onto the unit. Tighten the screws sufficiently to ensure that the unit is sealed airtight.

# 06 Ventilation ducts

## INSTALLER

### 06.A Maintenance frequency

- Your ventilation ducts need to be cleaned by an accredited installer.
- The contamination of the existing ventilation ducts can sometimes take on serious forms. It is therefore necessary to clean the ducts on a regular basis, namely every 5-6 years for the supply air and about every 8 years for the exhaust air ductwork. This can of course differ from situation to situation, depending on the extent of fouling.

### 06.B How to clean

1. Remove the vents.
2. Check the air ducts visually for contamination. Dust and/or grease can adhere to the first section of the duct.
3. Clean the ducts with a damp cloth and use a bio-degreaser or soap water as appropriate. Do not use solvents!



# 07 Control components and user controllers

**RESIDENT****INSTALLER**

## 07.A Maintenance frequency

- Operating and control components require no maintenance during their service life. However, operation may be impaired by air slot fouling. Therefore, as a resident, regularly remove the dust from the casing with a dry duster or with a vacuum cleaner if necessary.
- DUCO recommends a 3-yearly maintenance of its ventilation system control components by an accredited installer.

## 07.B Battery-powered control

The battery in a battery-powered controller lasts 3 to 5 years in normal use. Battery type: CR2430 – 3 V  
Unscrew the user controller from the wall and unscrew the lid at the back to open it in order to replace the battery.

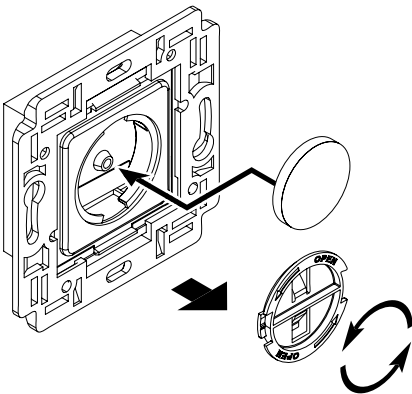

# 08 Kitchen box

## RESIDENT

As a resident, you need to carry out the inspection and cleaning yourself.

### 08.A Maintenance frequency

Check the Kitchen box (and vents) regularly (approximately once every 2 months) for fouling.

### 08.B How to clean

- Remove the inspection hatch by hand.
- Clean the removable inspection hatch with a vacuum cleaner and then with a damp cloth (soap and water (e.g. a general-purpose cleaner)).
- Clean the Kitchen Box with a damp cloth as soon as you notice any fouling. Caution: the IAV valve is a 24 V powered item.
- Take care not to change the setting and position of the vent control mechanism and the throttle valve. If more than one vent has been mounted on the Kitchen box, make sure that the vents are not interchanged and that they are therefore placed back in the original ventilation opening in the Kitchen box. All this may affect the flow rate and the proper functioning of the ventilation system.
- Fouling on the inside, including on the throttle valve of the Kitchen box, is best removed by sucking out or cleaning using a vacuum cleaner, brush or (damp) cloth. Carefully check also for fouling that may have accumulated in the corners. If so, remove it as well.
- The inside of the duct can be cleaned with a vacuum cleaner.
- Put the removable inspection hatch back onto the Kitchen box.

# 09 Service & warranty

The responsibility for warranty implementation lies in the first place with the installer or supplier where the DucoBox was bought. Always refer to the local installer or dealer if you have problems with the installation and/or operation of the DucoBox. Keep the serial number of the product nearby. You can find the serial number as follows:

## DucoBox Silent / DucoBox Focus

The sticker with the serial number is located inside the unit. Temporarily unplug the DucoBox and remove the lid. Afterwards, close the lid securely (press down all the corners) and put the plug back into the socket.

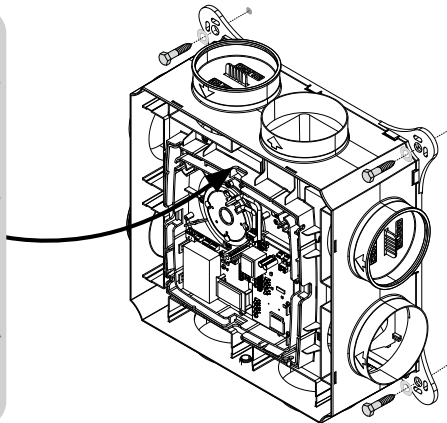

## DucoBox Energy

See label on top of the unit.

All warranty conditions concerning the DucoBox and DUCO ventilation systems can be found at [link.duco.eu/warranty-statement-duco-ventilation-systems](https://link.duco.eu/warranty-statement-duco-ventilation-systems).

# 10 In general

For more information, please contact:

DUCO Ventilation & Sun Control

Handelsstraat 19 – 8630 Veurne (Belgium)

Phone: +32/58/33.00.33

E-mail: [info@duco.eu](mailto:info@duco.eu) / [service@duco.eu](mailto:service@duco.eu)

Website: [www.duco.eu](http://www.duco.eu)